

# SOLE

FITNESS



*E55  
Elliptical*



*E25  
Elliptical*

## **OWNER'S MANUAL**

**PLEASE CAREFULLY READ THIS ENTIRE MANUAL BEFORE  
OPERATING YOUR NEW ELLIPTICAL!**

# ***Table of Contents***

Product Registration.....	2
Important Safety Instructions.....	3
Important Electrical Information.....	4
Important Operation Instructions.....	4
E25 Assembly Instructions.....	5
E55 Assembly Instructions.....	12
Operation of Your New Elliptical.....	20
Maintenance.....	34
Manufacturer’s Limited Warranty.....	35

***ATTENTION-THIS ELLIPTICAL IS INTENDED FOR RESIDENTIAL USE ONLY AND IS WARRANTED FOR THAT APPLICATION. ANY OTHER APPLICATION VOIDS THIS WARRANTY IN ITS ENTIRETY.***



**CONGRATULATIONS ON YOUR  
NEW ELLIPTICAL AND WELCOME  
TO THE SOLE FAMILY!**

Thank you for your purchase of this quality elliptical trainer from SOLE. Your new elliptical has been manufactured by one of the leading fitness manufacturers in the world and is backed by one of the most comprehensive warranties available. SOLE will do all we can to make your ownership experience as pleasant as possible for many years to come.

If you have any questions about your new product or questions about the warranty contact SOLE Fitness at 1-866-780-SOLE (7653). For SOLE service call 866-MYSOLE1 (697-6531)

Please take a moment at this time to record the name of the dealer, their telephone number, and the date of purchase below to make any future, needed contact easy. We appreciate your support and we will always remember that you are the reason that we are in business. Please complete and mail your registration card today and enjoy your new elliptical.

Yours in Health,  
SOLE Fitness

**Name of Dealer** \_\_\_\_\_  
**Telephone Number of Dealer** \_\_\_\_\_  
**Purchase Date** \_\_\_\_\_

***Product Registration***

**RECORD YOUR SERIAL NUMBER**

Please record the Serial Number of this fitness product in the space provided below.

**Serial Number** \_\_\_\_\_

**REGISTER YOUR PURCHASE**

The self-addressed product registration card must be completed in full and returned to SOLE. or visit [www.Soletreadmills.com](http://www.Soletreadmills.com) under the support tab to register online.

E25 / E55 / 2008 ver. A

# ***Important Safety Instructions***

**WARNING - Read all instructions before using this appliance.**

- Do not operate elliptical on deeply padded, plush or shag carpet. Damage to both carpet and elliptical may result.
- Keep children away from the elliptical. There are obvious pinch points and other caution areas that can cause harm.
- Keep hands away from all moving parts.
- Never operate the elliptical if it has a damaged cord or plug. If the elliptical is not working properly, call your dealer.
- Keep the cord away from heated surfaces.
- Do not operate where aerosol spray products are being used or where oxygen is being administered.
- Never drop or insert any object into any openings.
- Do not use outdoors.
- To disconnect, turn all controls to the off position, then remove the plug from the outlet.
- Do not attempt to use your elliptical for any purpose other than for the purpose it is intended.
- The hand pulse sensors are not medical devices. Various factors, including the user's movement, may affect the accuracy of heart rate readings. The pulse sensors are intended only as exercise aids in determining heart rate trends in general.
- Wear proper shoes. High heels, dress shoes, sandals or bare feet are not suitable for use on your elliptical. Quality athletic shoes are recommended to avoid leg fatigue.

**SAVE THESE INSTRUCTIONS - THINK SAFETY!**

## ***Important Electrical Information***

### **WARNING!**

- **NEVER** remove any cover without first disconnecting AC power supply.
- If A.C. voltage varies by ten percent (10%) or more, the performance of your elliptical may be affected. **Such conditions are not covered under your warranty.** If you suspect the voltage is low, contact your local power company or a licensed electrician for proper testing.
- **NEVER** expose this elliptical to rain or moisture. This product is **NOT** designed for Use outdoors, near a pool or spa, or in any other high humidity environment.

## ***Important Operation Instructions***

- **NEVER** operate this elliptical without reading and completely understanding the results of any operational change you request from the computer.
- Understand that changes in resistance do not occur immediately. Set your desired level on the computer console and release the adjustment key. The computer will obey the command gradually.
- **NEVER** use your elliptical during an electrical storm. Surges may occur in your household power supply that could damage elliptical components.
- Use caution while participating in other activities while using your elliptical such as watching television, reading, etc. These distractions may cause you to lose balance which may result in serious injury.
- Always hold on to a handrail or hand bar while making control changes.  
Do not use excessive pressure on console control keys. They are precision set to properly function with little finger pressure. Pushing harder is not going to make the unit go faster or slower. If you feel the buttons are not functioning properly with normal pressure, contact your **SOLE** dealer.

# Assembly Instructions (E25)

## ■ UNPACKING THE UNIT

1. Using a razor knife (Box Cutter) cut the outside, bottom edge of box along the dotted Line. Lift Box over the unit and unpack.
2. Carefully remove all parts from carton and inspect for any damage or missing parts. If damaged parts are found, or parts are missing, contact your dealer immediately.
3. Locate the hardware package. The hardware is separated into steps. Remove the tools first then remove the hardware for each step as needed to avoid confusion.

## STEP 1: CONSOLE MAST ASSEMBLY

1. Locate the Console Mast and Console Mast Cover and slide the Cover onto the Mast as far as it will go. Make sure the Console Mast Cover is facing the correct way.
2. At the top opening of the Main Frame of the elliptical is a Computer Cable. Unravel and straighten out the Computer Cable and feed it into the bottom of the console mast tube and out of the top opening.
3. Install the Console Mast into the receiving bracket in the top of the Main Frame. NOTE: there is one bolt already installed in the receiving bracket that will engage with the slot at the bottom of the Console Mast. This needs to be tightened at the end along with the three other console mast bolts.
4. Put the 1pc of 3/8" x 2T Split Washer onto the 1pc of 3/8" x 2-1/4" Hex Head Screw and the 2pcs of 3/8" x 23 x 1.5T Curved Washers onto the 2pcs of 3/8" x 3/4" Hex Head Screws. Install, and hand tighten, the Hex Head Screw through the left side of the receiving bracket into the Console Mast.  
**NOTE:** There is an electrical wire running through the Console Mast Tube. Be careful not to damage or pinch this Computer Cable during this procedure. Damage to the Console could result. Install, and hand tighten, the 2pc of 3/8" x 3/4" Hex Head Screws through the front of the receiving bracket into the Console Mast.
5. Using the 13/14m/m Wrench tighten the three bolts, and the fourth bolt which is pre-installed, firmly. These bolts should be tightened as much as you possibly can.
6. Locate the Console and the 4 pcs of M5 x 10m/m Phillips Head Screws.
7. There will be three electrical wire connectors at the top opening of the console mast, two 2 pin (hand pulse sensors), one 10 pin (main wire harness). Connect these to the mating connectors on the back of the console. The connectors are keyed so you cannot plug them in the wrong way so do not force them. The two, 2 pin connectors can be plugged into either connector on the back of the console.

8. Storing the excess wire back into the Console Mast, carefully install the Console onto the mounting plate of Console Mast and secure using the 4 pcs of M5 x 10m/m Phillips Head Screws.

### **STEP 2: HANDLE BAR ASSEMBLY**

1. Install the 2 pcs of 17m/m Wave Washers onto the Left and Right side of the Handle Bar axle.
2. Slide the Left and Right Handle Bars onto the appropriate side of the axle.
3. Put the 2 pcs of 5/16" x 23 x 1.5T Flat Washers onto the 2 pcs of 5/16" x 15m/m Hex Head Screws and install, and tighten, in the threaded holes in the ends of the axle.

### **STEP 3: CONNECTING ARM ASSEMBLY**

1. Align the hole in the rod end of the left Connecting arm with the hole in the bracket of the left Handle Bar. The rod end should be on the inside of the Handle Bar bracket. Make sure the ty-wrap is removed from the rod end and the sleeve spacer does not fall out during assembly. Take 1pc of 5/16" x 1-1/4" Hex Head Bolt and install it through the Handle Bar bracket and the rod end. Install 1pc of 5/16" x 20 x 1.5T Flat Washer, 5/16" x 7T Nyloc Nut on the 5/16" x 1-1/4" Hex Head Bolt and tighten as tight as possible using the two 12m/m Wrenches provided. Repeat the procedure for the right side Pedal /Connecting Arm.

### **STEP 4: PLASTICS ASSEMBLY**

1. Install the Connecting Arm Covers (L) (R) over the connection of the rod end and Handle Bars with 4pcs of M5 x 15m/m Button Head Socket Screws and 2pcs of 3.5x10m/m Self Tapping Screw by using the Short Phillips Screw Driver.
2. Install the 2pcs of Wheel Covers using the 4pcs of M5x15m/m Phillips Head Screws.
3. Locate the 2 pcs of Rear Stabilizer Cover and 2 pcs of Middle Stabilizer Cover for the Rear Rail Assembly and install with 4 pcs of M5 x 15m/m Screws by using the Phillips Head Screw Driver. Then install front stabilizer cover with 2 pcs of M5 x 15m/m Screws by using the Phillips head screwdriver.
4. Install the Front Handle Bar Cover (L & R) and Rear Handle Bar Cover (L & R) over the Handle Bars axle connections with the 6 pcs of  $\Psi$  3.5x10m/m Self Tapping Screws by using Phillips Head Screw Driver.

PLEASE ENSURE ALL FASTENERS ARE TIGHT AFTER THE COMPONENTS HAVE BEEN ASSEMBLED.

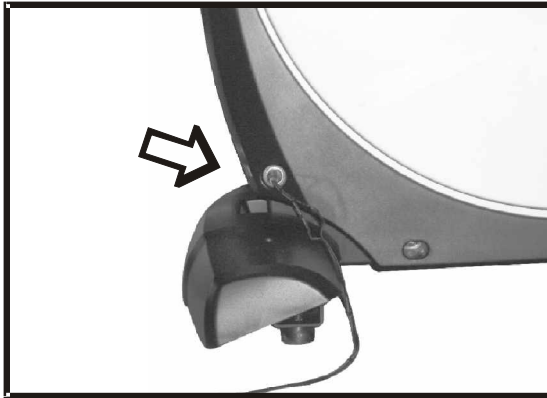

**POWER CONNECTOR LOCATED  
ON FRONT, LEFT HAND SIDE OF  
UNIT.**

### **Transportation**

The elliptical is equipped with two transport wheels which are engaged when rear of the Elliptical is lifted.



# Assembly drawing (E25)

## Step 1

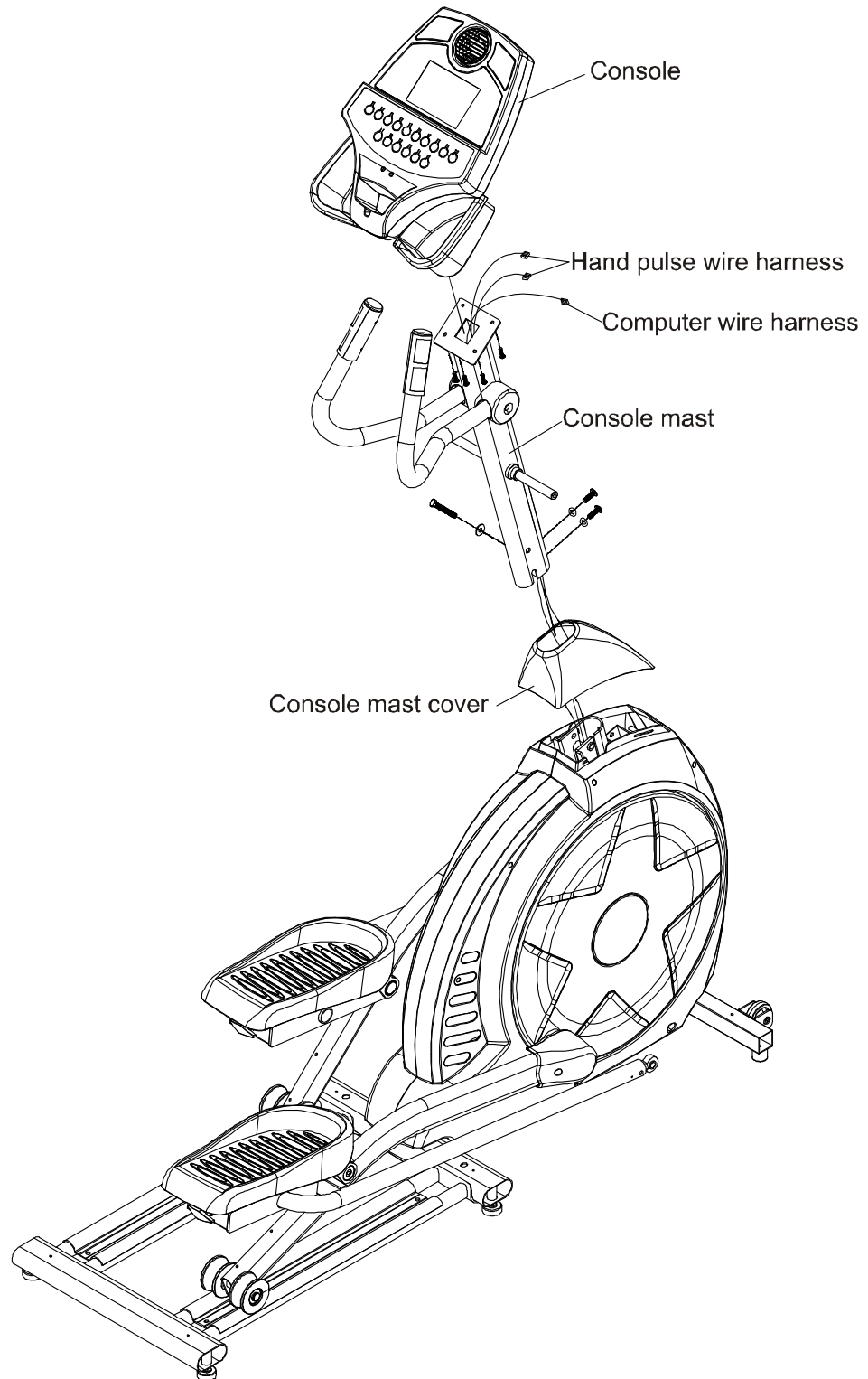

## Step 2

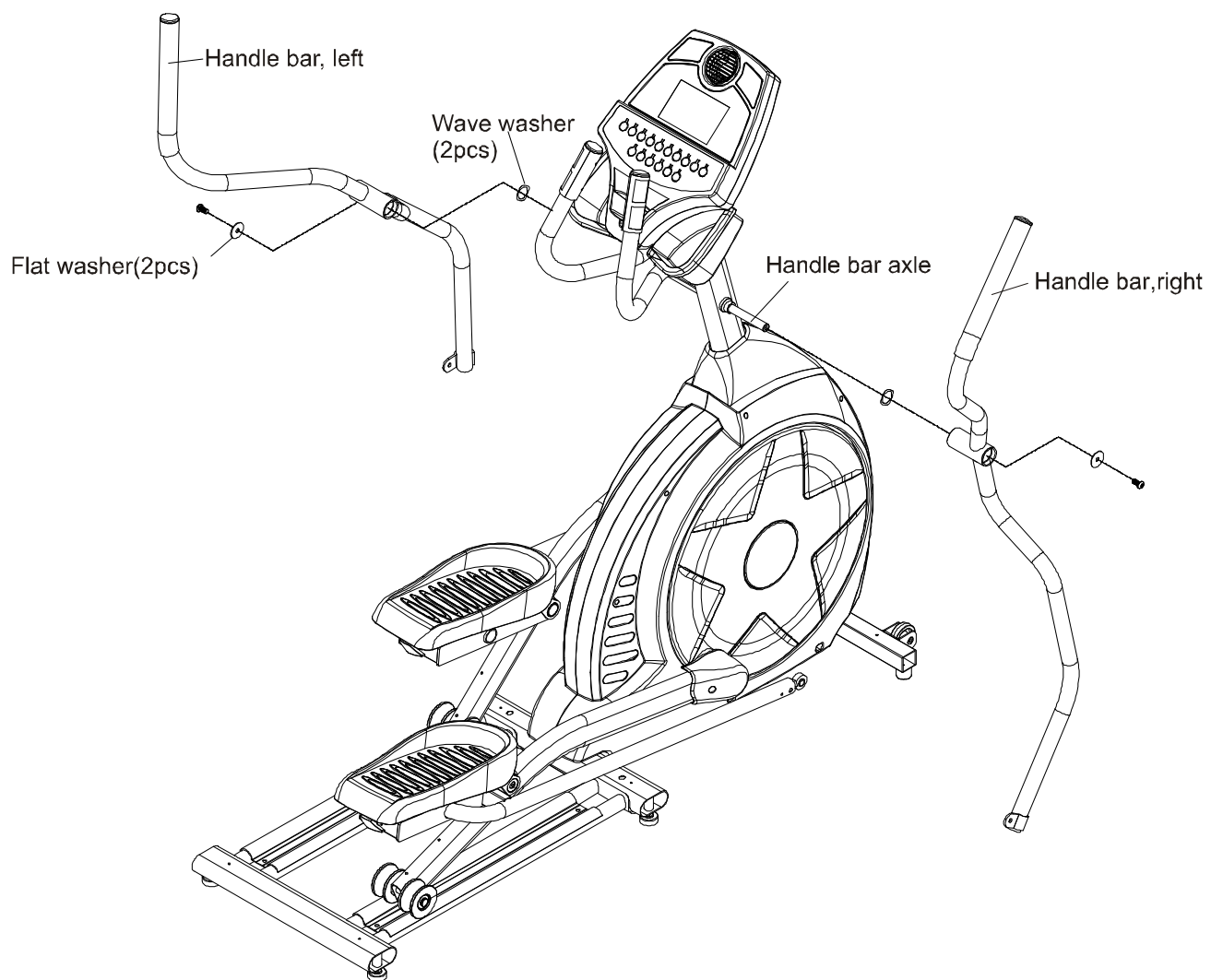

### Step3

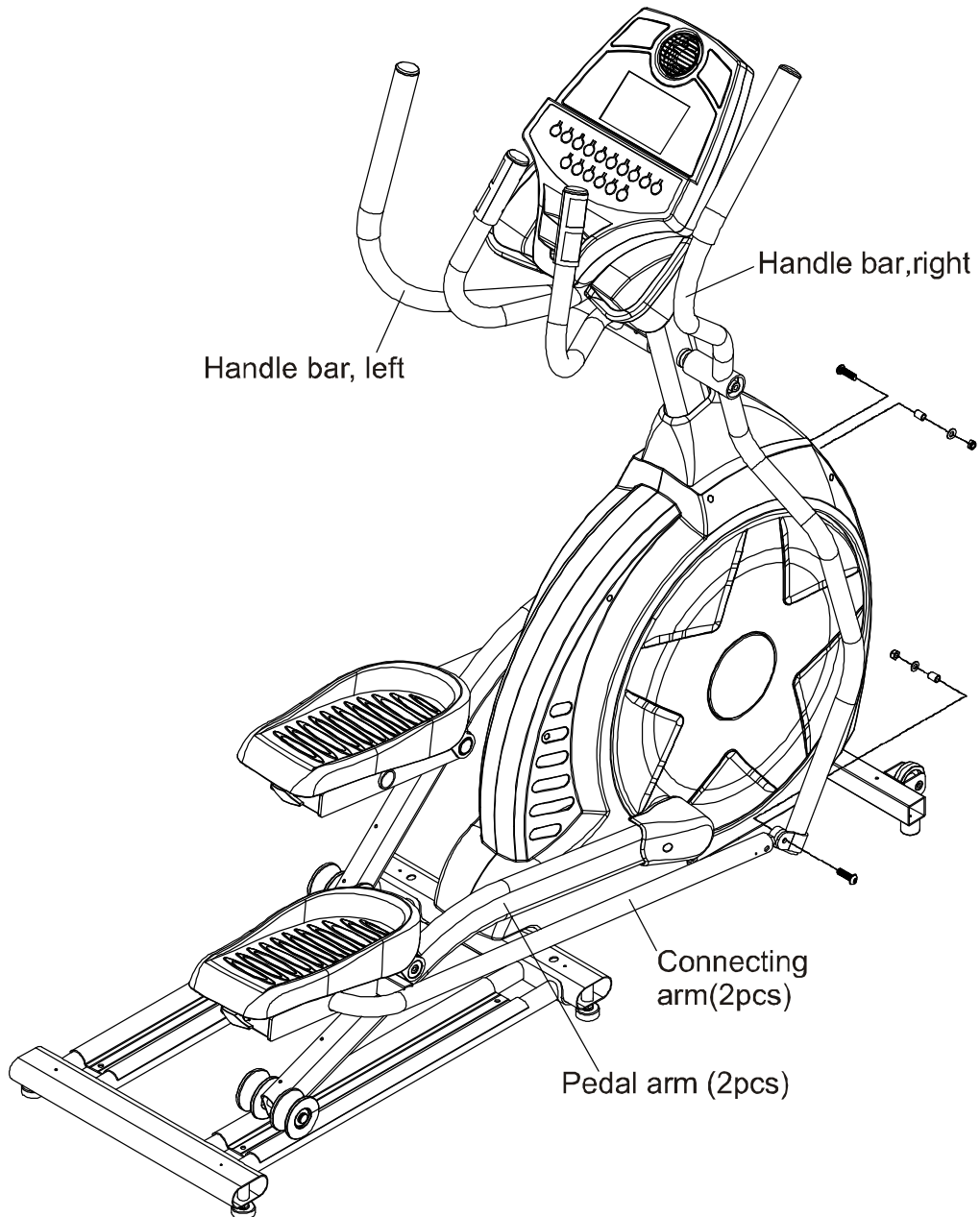

## Step 4

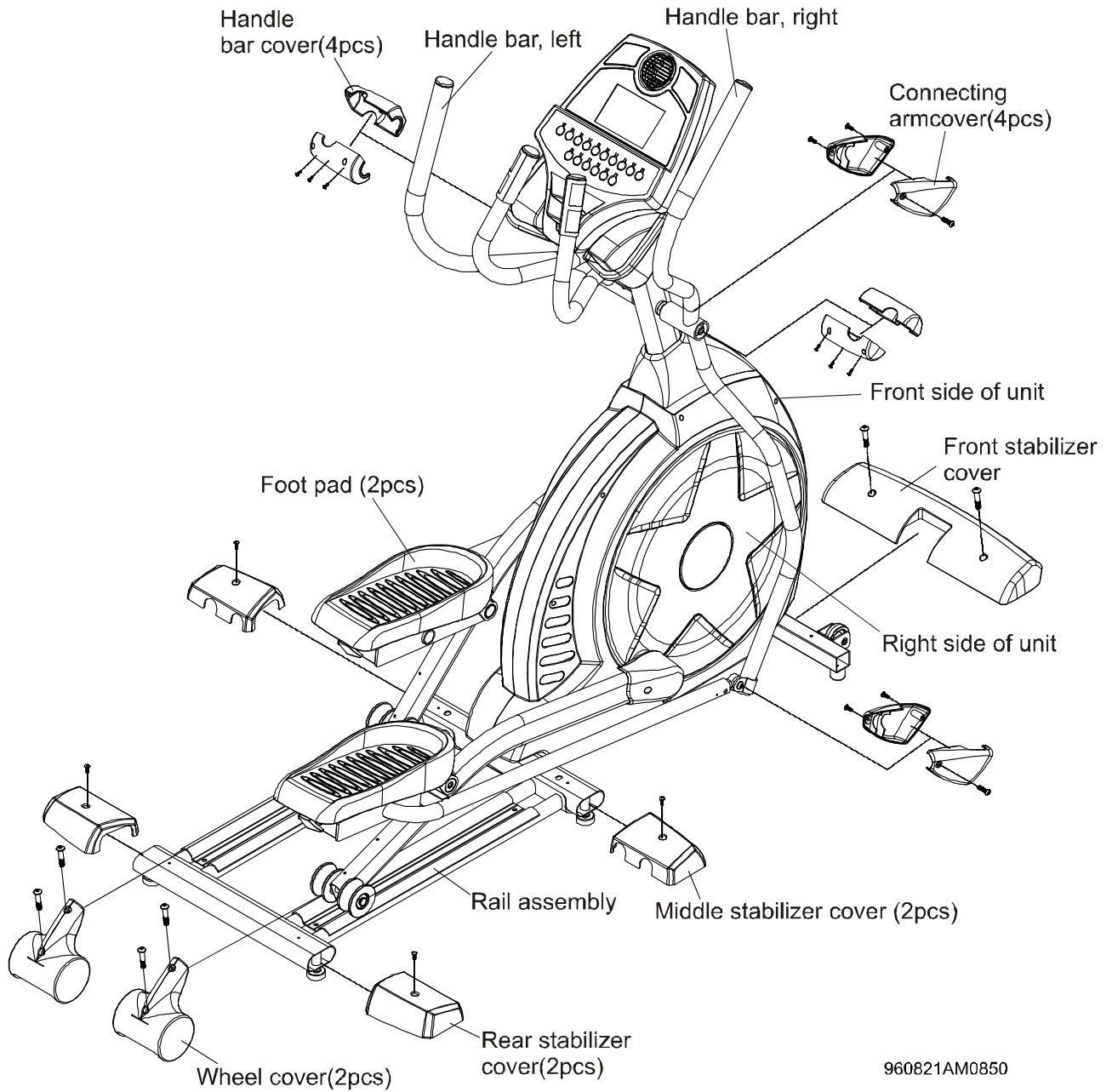

# Assembly Instructions (E55)

## ■ UNPACKING THE UNIT

1. Using a razor knife (Box Cutter) cut the outside, bottom edge of box along the dotted Line. Lift Box over the unit and unpack.
2. Carefully remove all parts from carton and inspect for any damage or missing parts. If damaged parts are found, or parts are missing, contact your dealer immediately.
3. Locate the hardware package. The hardware is separated into steps. Remove the tools first then remove the hardware for each step as needed to avoid confusion.

## STEP 1: REAR RAIL ASSEMBLY

1. Place the main frame of the elliptical on the floor and place the rear rail assembly underneath it so the mounting holes line up and the wheels are on the tracks.
2. Put the two 3/8" x 19mm flat washers on the two 3/8" x 2-1/4" hex head bolts and hand-tighten them through the top of the rear stabilizer tube (main frame), into the rear rail assembly by using the 13/14 m/m Wrench.
3. Put the four 3/8" x 23mm curved washer on the four 3/8" x 3-3/4" hex head bolts and hand-tighten them through the front of the rear stabilizer tube (Main Frame), into the rear rail assembly . Now tighten all six bolts as much as you possibly can.
4. Install Front Stabilizer Cover with 2pcs of M5 X 5 mm Phillips head screws by using the Phillips head screw driver.

## STEP 2: CONSOLE MAST ASSEMBLY

1. Locate the console mast and console mast cover and slide the cover onto the mast as far as it will go. Make sure the console mast cover is facing the correct way.
2. At the top opening of the Main Frame, there is a computer cable tied with a guiding wire. Unravel the wire and feed the computer cable into the bottom of the console mast tube and out of the top opening.
3. Install the console mast into the receiving bracket on the top of the Main Frame. NOTE: there is one bolt already installed in the receiving bracket that will engage with the slot at the bottom of the Console Mast. This needs to be tightened at the end, along with the three other console mast bolts.
4. Put the one 3/8" split washer onto the 1pc of 3/8" x 2-1/4" hex head bolt and the two 3/8" x 23 mm curved washers onto the two 3/8" x 3/4" hex head bolts. Install, and hand tighten them into the console mast. The hex head bolt should go through the left side of the receiving bracket and the Console Mast and thread into the right side of the receiving bracket.  
**NOTE:** The computer cable runs through the console mast tube. Be careful not to damage or pinch this cable during this procedure as damage to the Console Assembly could result. Install, and hand tighten the two 3/8" x 3/4" hex head bolts with curved washers through the front of the receiving bracket into the Console Mast.
5. Using the 13/14m/m Wrench to tighten the three bolts, and the fourth bolt, which is pre-installed, firmly. **These bolts should be tightened as much as you**

**possibly can.**

6. Locate the console assembly and tighten it with the four M5 x 10 m/m phillips head screws by using the Phillips Head Screw Driver.
7. There are three connectors at the top opening of the Console Mast, two hand pulse cables and one computer cable. Connect these to the mating connectors on the back of the console assembly. Do not force them while connecting as the connectors are keyed so that you cannot plug them in the wrong way.
8. Store the excessive cable back into the console mast and carefully install the Console Assembly onto the mounting plate of console mast and secure with the four M5 x 10m/m phillips head screws by using philips head screw drive.

**STEP 3: HANDLE BAR ASSEMBLY**

1. Install the two 25mm wave washers onto the handle bar axle (part of the console mast).
2. Slide the left and right handle bars onto the appropriate side of the axle.
3. Put the two 3/8" x 30mm flat washers onto the two 3/8" x 3/4" hex head bolts and install into the threaded holes in the ends of the axle by using the 13/14mm Wrench.
4. Install the front left handle bar cover and rear left handle bar cover onto the left handle bar with the four 3.5x12mm self tapping screws by using the Phillips Head Screw Driver.
5. Repeat the step 6 to install the front right handle bar cover and rear right handle bar cover onto the right handle bar.

**STEP 4: PEDAL / CONNECTING ARM ASSEMBLY**

1. Align the hole in the rod end of the left connecting arm with the hole in the bracket of the left Handle Bar. Make sure the ty-wrap is removed from the rod end and the sleeve spacer does not fall out during assembly. Take one 5/16" x 1-1/4" hex head bolt and install it through the handle bar bracket and the rod end. Install one 5/16" x 20 mm flat washer and 5/16" Nyloc nut on the 5/16" x 1-1/4" hex head bolt and tighten as tight as possible using the two 12m/m wrenches provided. Repeat the procedure for the right side pedal /connecting arm.
2. Install the connecting arm covers over the connection of the rod end and handle bars eight M5 x 15m/m Phillips Head Screws and eight 3.5x12m/m self tapping screws by using the phillips head screw driver.
3. Install the two wheel covers over the urethane slide wheels with the four M5x12mm phillips head screws and tighten them.
4. Install the four stabilizer covers, on the rail assembly with the four M5x15mm phillips head screws.

PLEASE ENSURE ALL FASTENERS ARE TIGHT AFTER THE COMPONENTS HAVE BEEN ASSEMBLED.

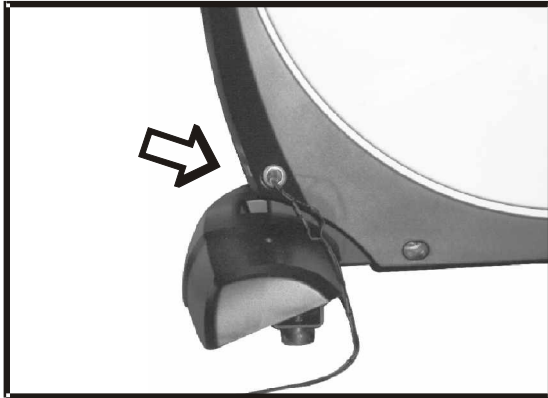

**POWER CONNECTOR LOCATED ON FRONT, LEFT HAND SIDE OF UNIT.**

### **Transportation**

The elliptical is equipped with two transport wheels which are engaged when rear of the Elliptical is lifted.

# Assembly drawing (E55)

## Step 1

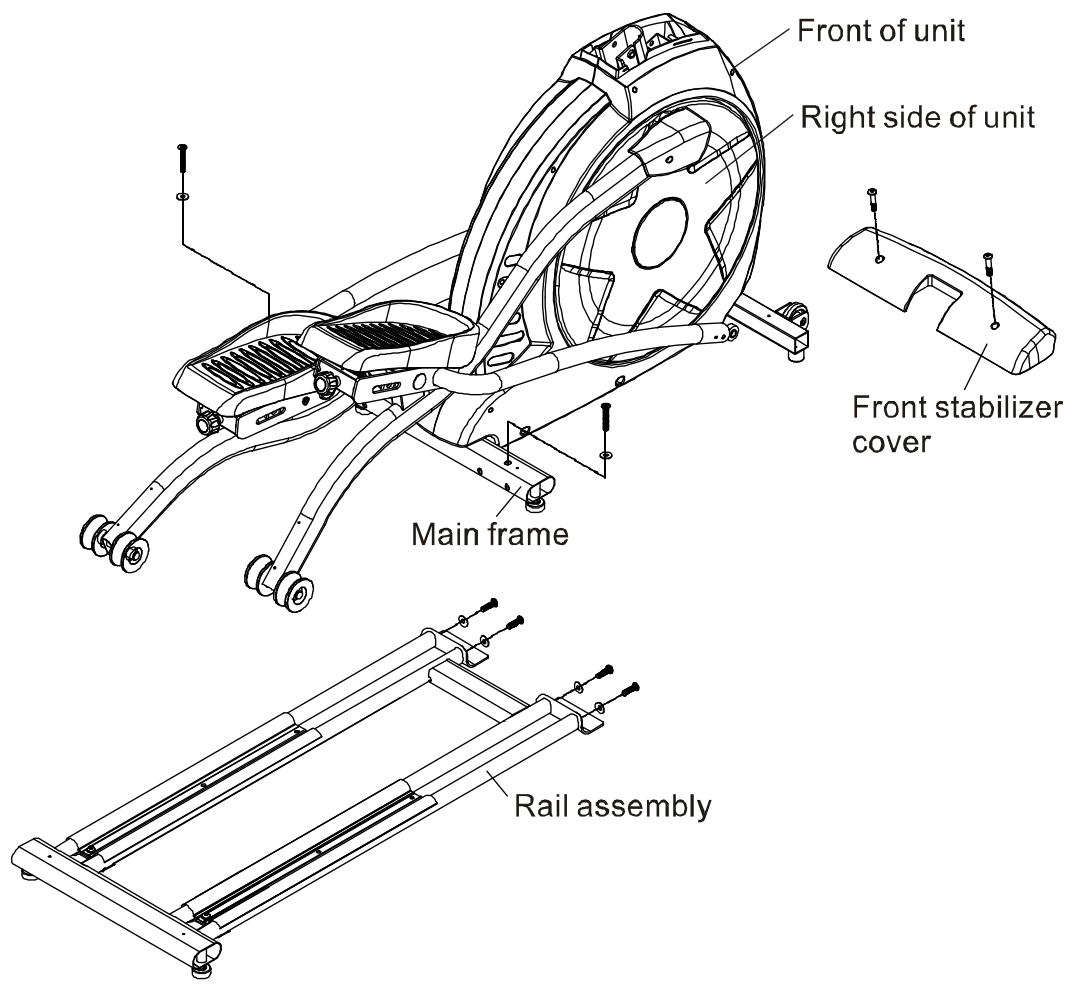



## Step 2

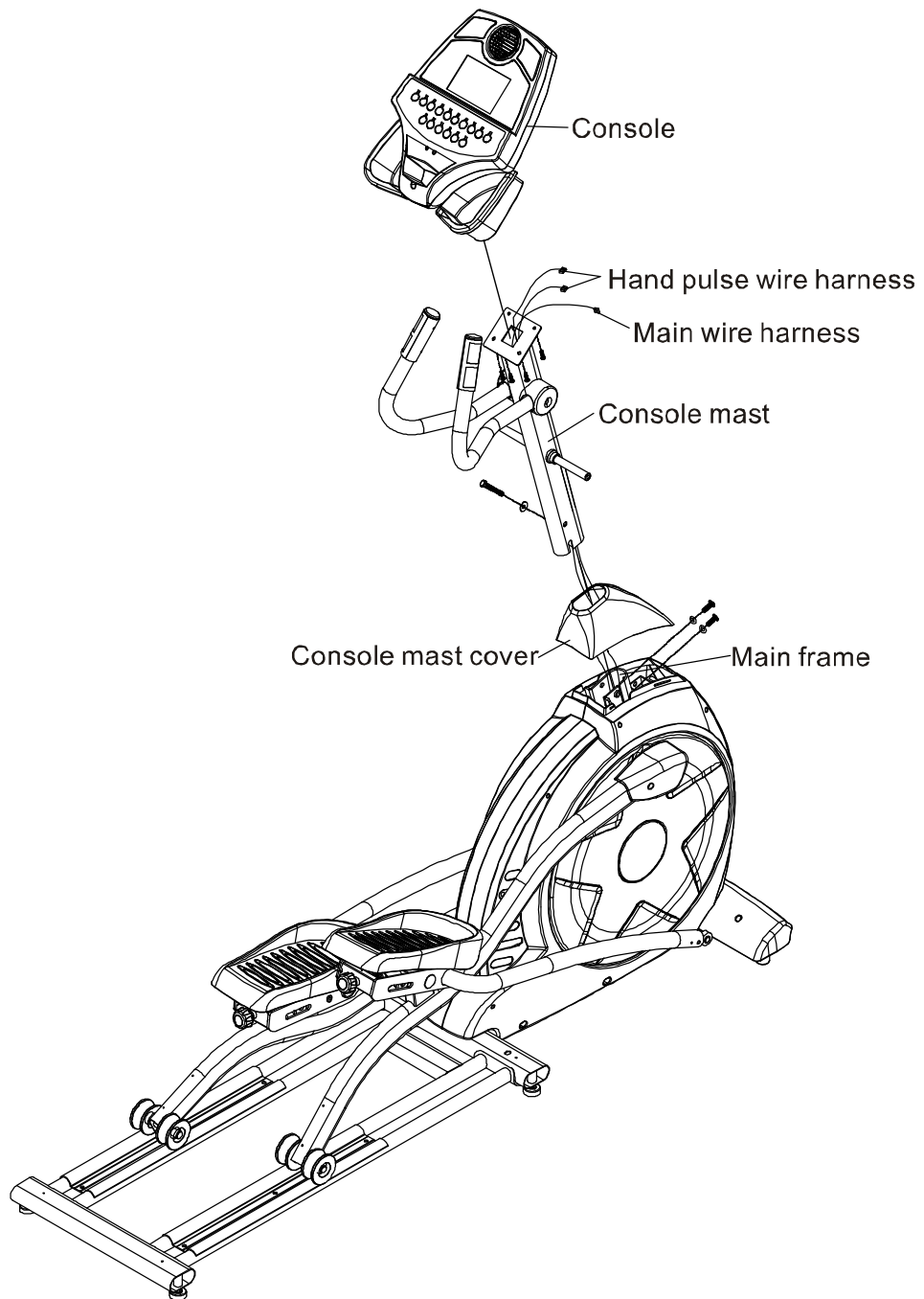

### Step3

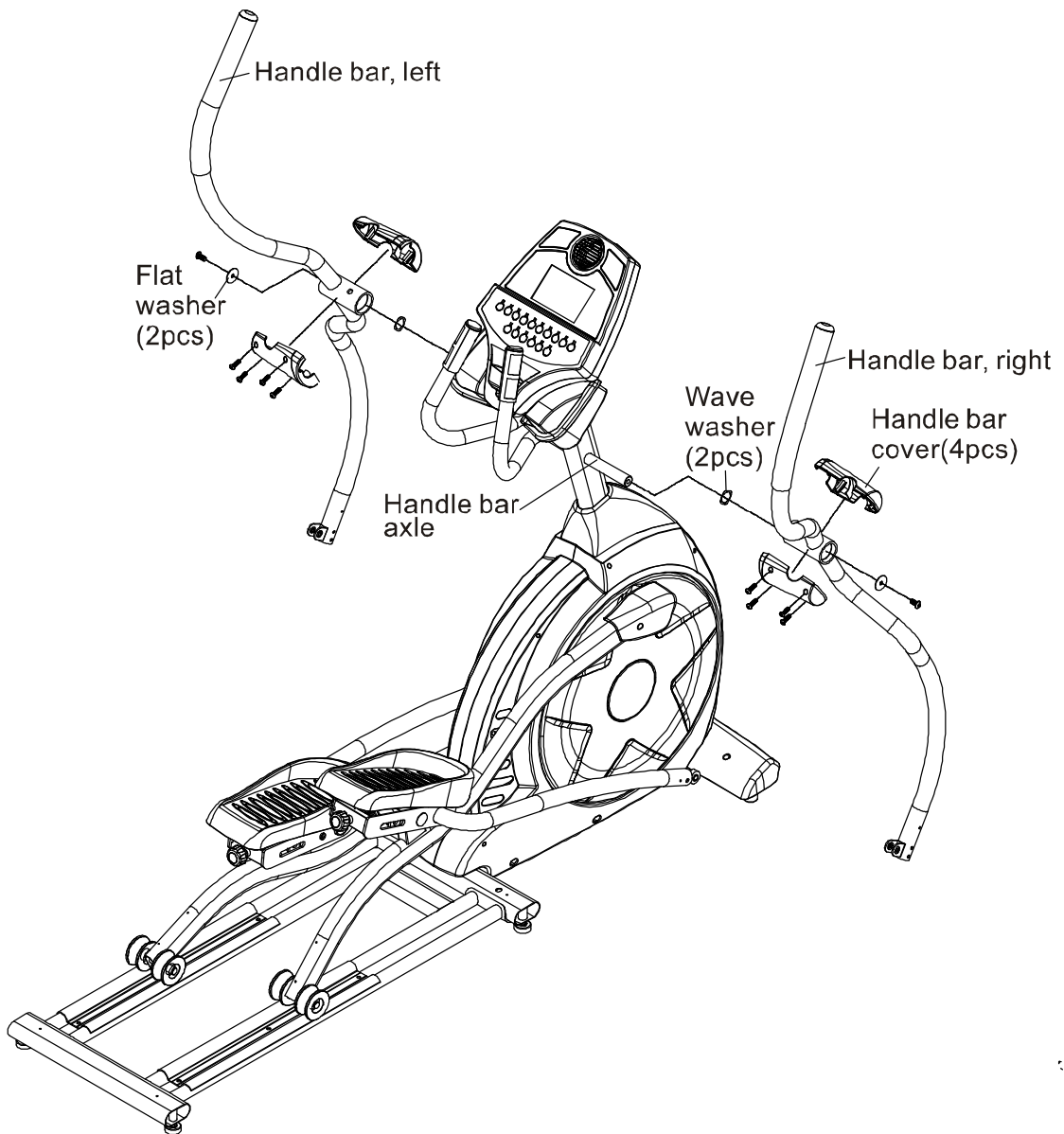

# Step 4

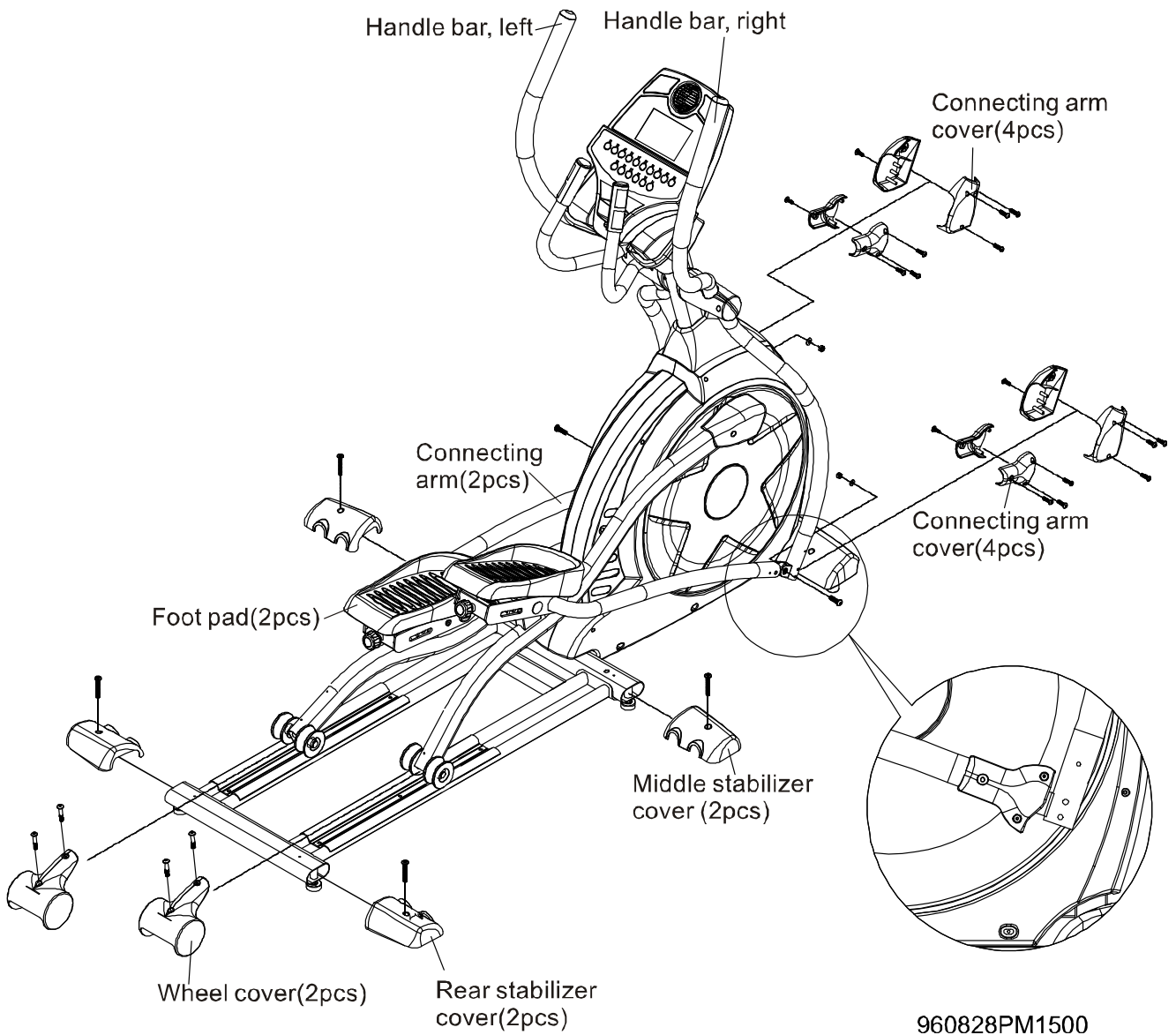

# Features

## Adjustable foot pedals, and correctly aligned orthopedic foot pads

Through research performed with a leading sports scientist and physical rehabilitation expert; SOLE engineering has developed a breakthrough in pedal design. No other elliptical, at any price, offers these unique features. The history of elliptical use over the past few years tells us that many users suffer from numb toes while working out on elliptical trainers. Many other users complain of ankle, Achilles tendon, knee and/or hip pain. While researching a solution to these common problems SOLE engineers consulted Richard DeKok, P.T., M.T.C., of St. Bernard's Industrial Rehabilitation Center in Jonesboro Arkansas. Together we identified the inherent problem in elliptical designs and developed solutions to solve the problems. What we found is that when you use an elliptical you tend to push outward during the power stroke and not just straight back. This causes stress on the outer part of the foot and throws off the natural alignment of the joints. The second problem we found is that many people tend to stay up on the ball of their foot during the elliptical motion. Our solutions were simple but effective:

- I The first solution was to add a 2-degree inward angle to the footpads. This might sound simple but what it does is puts the users joints back into a neutral alignment. This eases the over stressing of the ankles, knees and hips.  
The second solution was to make the foot pedal adjustable to the user's style of pedaling the elliptical. We achieved this by adding an adjustment that allows the angle of the footpad to be changed. Because everybody is different, and there are as many styles to pedal an elliptical as there are people, we found there is no one angle that fit every user. Some users would be up on the balls of their feet, resulting in numb toes, so we decided to let the user adjust the back of the foot pad upward to support the heel, taking the pressure off of the nerves in the balls of the feet and the Achilles tendon. The result was no more numb toes. Some users are uncomfortable at this angle so for them we designed in three different adjustable angles so they could find one that feels best for them.
- I **E25:** There are three settings available by pulling on the red quick release handle under the rear of each footpad. The lowest setting will set the footpads at zero (0) degrees, or flat, at the bottom of the elliptical stroke. The second position sets the footpad to five (5) degrees and the top position sets the footpads to ten (10) degrees.
- I **E55:** There is a red knob under the footpads that will allow you to infinitely adjust the footpad angle from 0 to 10 degrees. There is a scale on the side that shows you the angle position.

A great side benefit of the adjustable footpad angle is that you end up working different muscle groups. At the highest angle you will work the quadriceps more. At the lowest angle you work the hamstrings and glutes harder. Not a bad perk!

# Operation of Your Elliptical

## Getting familiar with the control panel

### ■ E25 Console

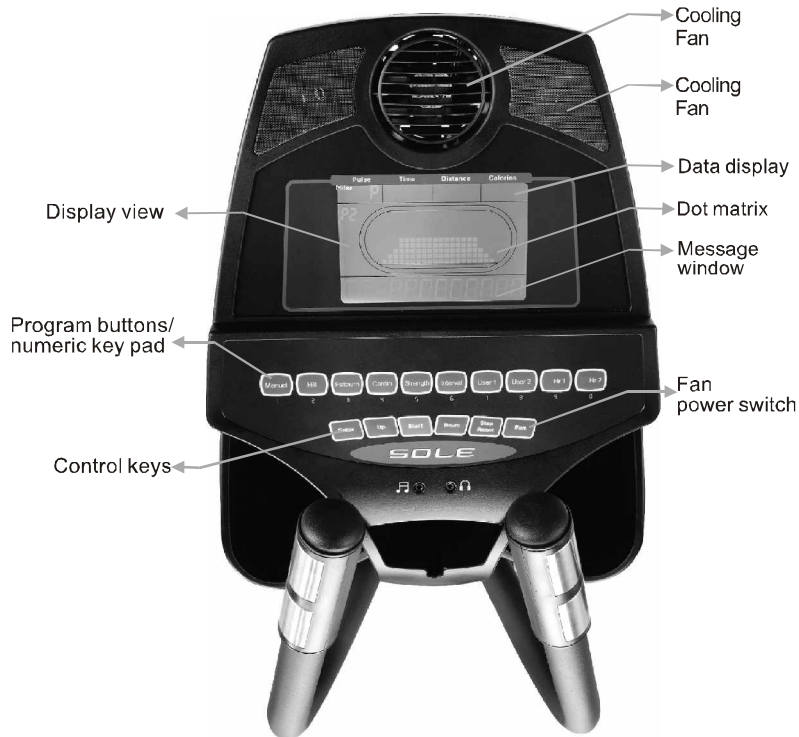

### ■ E55 Console

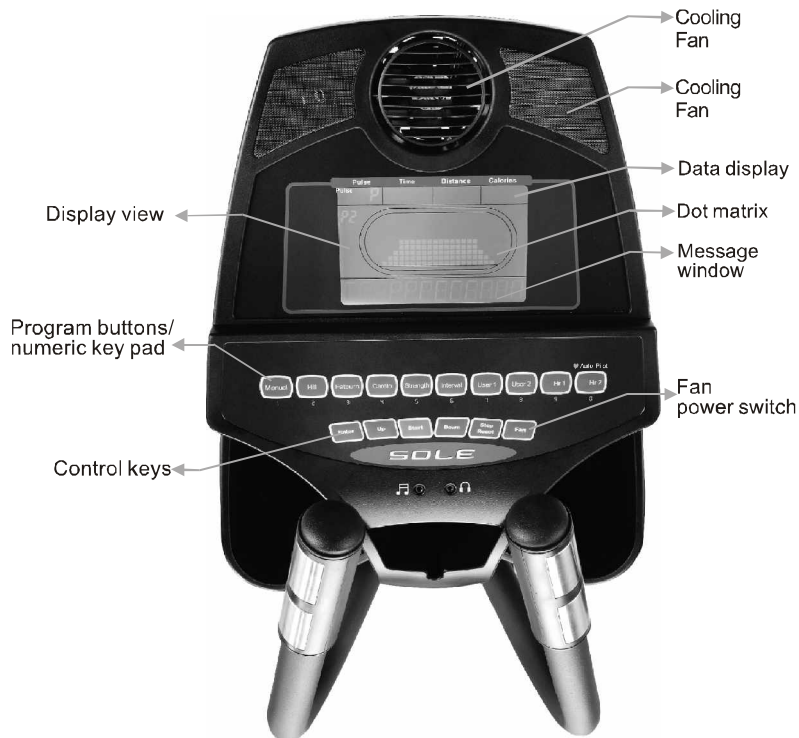

## Power up

The Elliptical is supplied with an external power supply. When power is connected to the Elliptical, the console will automatically power up. If there is no input to the console for 20 minutes the console will go to stand-by mode. In stand-by mode the console display will turn off. To turn the console on press any key.

When initially powered on the console will perform an internal self test. During this time all the lights will turn on. When the lights go off the dot matrix display will show a software version (i.e.: VER 1.0) and the message window will display an odometer reading. The odometer reading displays how many hours the elliptical has been used and how many virtual miles the elliptical has gone. The display will look like this: ODO 123 MI 123 HRS.

The odometer will remain displayed for only a few seconds then the console will go to the start up display. The dot matrix display will be scrolling through the different profiles of the programs and the message window will be scrolling the start up message. You may now begin to use the console.

## Console Operation

### Quick Start

This is the quickest way to start a workout. After the console powers up you just press the Start key to begin, this will initiate the Quick Start mode. In Quick Start the Time will count up from zero and the workload may be adjusted manually by pressing the Up or Down buttons. The dot matrix display will have only the bottom row lit at first. As you increase the work load more rows will light indicating a harder workout. The elliptical will get harder to pedal as the rows increase.

### Basic information

The **Message Window** will initially be displaying Speed information. Each time the Enter button is pressed the next set of information will appear, four windows in all. In order: Speed in RPM and MPH, Work Level and Watts. If the Enter button is pressed during the Level and Watts display the Scan light will come on and the message window will show each set of data for four seconds then switch to the next set of data in a continuous loop. Pressing the Enter button again will bring you back to the beginning.

The Elliptical has a built in heart rate monitoring system. Simply grasping the hand pulse sensors on the stationary handle bars, or wearing the heart rate transmitter, will start the **Heart Icon** blinking (this may take a few seconds). The Pulse Display Window will display your heart rate, or Pulse, in beats per minute.

The **Stop/Reset** button actually has several functions. Pressing the Stop/Reset key once during a program will **Pause** the program for 5 minutes. If you need to get a drink, answer the phone or any of the many things that could interrupt your workout, this is a great feature. To resume your workout during Pause just press the Start key. If the Stop/Reset button is pressed twice during a workout the program will end and the console will return to the start up screen. If the Stop/Reset key is held down for 3 seconds the console will perform a

complete **Reset**. During data entry for a program the Stop/Reset key performs a **Previous Screen** function. This allows you to go back one step in the programming each time you press the Stop/Reset key.

The **Program Keys** are used to preview each program. When you first turn the console on you may press each program key to preview what the program profile looks like. If you decide that you want to try a program, press the corresponding program key and then press the Enter key to select the program and enter into the data setting mode.

The program keys also act as a **Number Key Pad** when you are in the data setting mode. Under each program key is a number. If you are setting new data, such as Age, weight etc., you can use these keys to enter the numbers quickly.

The E series consoles include a built-in fan to help keep you cool. To turn the fan on, [press the fan button on the front of the console](#).

## Programming the console

Each of the programs can be customized with your personal information and changed to suit your needs. Some of the information asked for is necessary to ensure the readouts are correct. You will be asked for your **Age** and **Weight**. Entering your **Age** is necessary during the Heart Rate control programs to ensure the correct settings are in the program for your Age. Otherwise the work settings could be too high or low for you. Entering your **Weight** aides in calculating a more correct **Calorie** reading. Although we cannot provide an exact calorie count we do want to be as close as possible.

**A message about Calories:** Calorie readings on every piece of exercise equipment, whether it is in a gym or at home, are not accurate and tend to vary widely. They are meant only as a guide to monitor your progress from workout to workout. The only way to measure your calorie burn accurately is in a clinical setting connected to a host of machines. This is because every person is different and burns calories at a different rate. Some good news is that you will continue to burn calories at about the same rate as during exercise for 20-30 minutes after you have finished exercising!

## Entering/Changing Settings

When you enter a program, by pressing a program key, then enter key, you have the option of entering your own personal settings. If you want to workout without entering new settings then just press the Start key. This will bypass the programming of data and take you directly to the start of your workout. If you want to change the personal settings then just follow the instructions in the message window. If you start a program without changing the settings the default, or saved, settings will be used.

The default computer settings are: Age = 35, Weight = 155 Lbs., Time = 30:00, Max Level, each program has a different maximum work level: Hill = 7, Fatburn = 5, Cardio = 7, Strength = 8, Interval = 7.

NOTE: Age and Weight default settings will change when you enter a new number. So the



last Age and Weight entered will be saved as the new default settings. If you enter your Age and Weight the first time you use the Elliptical you will not have to enter it every time you work out unless either your Age or Weight changes or someone else enters a different Age and Weight.

## Manual

The Manual program works as the name implies; manually. This means that you control the workload yourself and not the computer. To start the Manual program follow the instructions below or just press the Manual button then the Enter button and follow the directions in the message window.

1. Press the **Manual** key then press the **Enter** key.
2. The message window will ask you to enter your **Age**. You may enter your Age, using the Up and Down keys or the numeric key pad, then press the Enter key to accept the new number and proceed on to the next screen.
3. You are now asked to enter your **Weight**. You may adjust the Weight number using the Up and Down keys or the numeric key pad, then press enter to continue.
4. Next is **Time**. You may adjust the Time and press enter to continue.
5. Now you are finished editing the settings and can begin your workout by pressing the Start key. You can also go back and modify your settings by pressing the Enter key.  
NOTE: At any time during the editing of Data you can press the Stop key to go back one level, or screen.
6. Once the program starts you will be at level one. This is the easiest level and it is a good idea to stay at level one for a while to warm up. If you want to increase the work load at any time press the Up key; the Down key will decrease the work load.
7. During the Manual program you will be able to scroll through the data in the message window by pressing the **Enter key**.
8. When the program ends you may press Start to begin the same program again or Stop to exit the program or you can save the program you just completed as a **custom user program** by pressing a User key and following the instructions in the message window.

## Preset Programs

The Elliptical has five different programs that have been designed for a variety of workouts. These five programs have factory preset profiles for achieving different goals. The initial built-in level of difficulty for each program is set to a relatively easy level. You may adjust the level of difficulty for each program before beginning by following the instructions in the message window after selecting your program.



## The Programs

### HILL

The **Hill** program simulates going up and down a hill. The resistance in the pedals will steadily increase and then decrease during the program. To start the Hill program follow the instructions below or just press the Hill button then the Enter button and follow the directions in the message window.

1. Press the **Hill** key then press the **Enter** key.
2. The message window will ask you to enter your **Age**. You may enter your Age, using the Up and Down keys or the numeric key pad, then press the Enter key to accept the new number and proceed on to the next screen.
3. You are now asked to enter your **Weight**. You may adjust the Weight number using the Up and Down keys or the numeric key pad, then press enter to continue.
4. Next is **Time**. You may adjust the Time and press enter to continue.
5. Now you are asked to adjust the **Max Level**. This is the peak exertion level you will experience during the program, at the top of the hill. The factory setting is level seven. Adjust the level and then press enter.
6. Now you are finished editing the settings and can begin your workout by pressing the Start key. You can also go back and modify your settings by pressing the Enter key. NOTE: At any time during the editing of Data you can press the Stop key to go back one level, or screen.
7. If you want to increase or decrease the work load at any time during the program press the Up or Down key. This will only affect the workload for the present position in the profile. When the profile changes to the next column it will return to the preset work level.
8. During the Hill program you will be able to scroll through the data in the message window by pressing the **Enter key**.
9. When the program ends you may press Start to begin the same program again or Stop to exit the program or you can save the program you just completed as a **custom user program** by pressing a User key and following the instructions in the message window.

### Fat Burn

The **Fat Burn** program is designed, as the name implies, to maximize the burning of fat. There are many schools of thought on the best way to burn fat but most experts agree that a lower exertion level that stays steady is the best. The absolute best way to burn fat is to keep your heart rate at around 60% to 70% of its maximum potential. This program does not use heart rate but simulates a lower, steady, exertion workout.

To start the Fat Burn program follow the instructions below or just press the Fat Burn button then the Enter button and follow the directions in the message window.

1. Press the **Fat Burn** key then press the **Enter** key.
2. The message window will ask you to enter your **Age**. You may enter your Age, using the Up and Down keys or the numeric key pad, then press the Enter key to accept the new number and proceed on to the next screen.

3. You are now asked to enter your **Weight**. You may adjust the Weight number using the Up and Down keys or the numeric key pad, then press enter to continue.
4. Next is **Time**. You may adjust the Time and press enter to continue.
5. Now you are asked to adjust the **Max Level**. This is the peak exertion level you will experience during the program. The factory setting is level five. Adjust the level and then press enter.
6. Now you are finished editing the settings and can begin your workout by pressing the Start key. You can also go back and modify your settings by pressing the Enter key. NOTE: At any time during the editing of Data you can press the Stop key to go back one level, or screen.
7. If you want to increase or decrease the work load at any time during the program press the Up or Down key. This will only affect the workload for the present position in the profile. When the profile changes to the next column it will return to the preset work level.
8. During the Fat Burn program you will be able to scroll through the data in the message window by pressing the **Enter key**.
9. When the program ends you may press Start to begin the same program again or Stop to exit the program or you can save the program you just completed as a **custom user program** by pressing a User key and following the instructions in the message window.

## Cardio

The **Cardio** program is designed to increase your Cardio vascular function. This is, simply said, exercise for your heart and lungs. It will build up your heart muscle and increase blood flow and lung capacity. This is achieved by incorporating a higher level of exertion with slight fluctuations in work. To start the Cardio program follow the instructions below or just press the Cardio button then the Enter button and follow the directions in the message window.

1. Press the **Cardio** key then press the **Enter** key.
2. The message window will ask you to enter your **Age**. You may enter your Age, using the Up and Down keys or the numeric key pad, then press the Enter key to accept the new number and proceed on to the next screen.
3. You are now asked to enter your **Weight**. You may adjust the Weight number using the Up and Down keys or the numeric key pad, then press enter to continue.
4. Next is **Time**. You may adjust the Time and press enter to continue.
5. Now you are asked to adjust the **Max Level**. This is the peak exertion level you will experience during the program. The factory setting is level seven. Adjust the level and then press enter.
6. Now you are finished editing the settings and can begin your workout by pressing the Start key. You can also go back and modify your settings by pressing the Enter key. NOTE: At any time during the editing of Data you can press the Stop key to go back one level, or screen.
7. If you want to increase or decrease the work load at any time during the program press the Up or Down key. This will only affect the workload for the present position in the profile. When the profile changes to the next column it will return to the preset work level.
8. During the Cardio program you will be able to scroll through the data in the message window by pressing the **Enter key**.

9. When the program ends you may press Start to begin the same program again or Stop to exit the program or you can save the program you just completed as a **custom user program** by pressing a User key and following the instructions in the message window.

## Strength

The **Strength** program is designed to increase muscular strength in your lower body. This program will steadily increase in resistance to a high level and then keeps you there. This is designed to strengthen and tone your legs and gluteus. To start the Strength program follow the instructions below or just press the Strength button then the Enter button and follow the directions in the message window.

1. Press the **Strength** key then press the **Enter** key.
2. The message window will ask you to enter your **Age**. You may enter your Age, using the Up and Down keys or the numeric key pad, then press the Enter key to accept the new number and proceed on to the next screen.
3. You are now asked to enter your **Weight**. You may adjust the Weight number using the Up and Down keys or the numeric key pad, then press enter to continue.
4. Next is **Time**. You may adjust the Time and press enter to continue.
5. Now you are asked to adjust the **Max Level**. This is the peak exertion level you will experience during the program. The factory setting is level eight. Adjust the level and then press enter.
6. Now you are finished editing the settings and can begin your workout by pressing the Start key. You can also go back and modify your settings by pressing the Enter key. NOTE: At any time during the editing of Data you can press the Stop key to go back one level, or screen.
7. If you want to increase or decrease the workload at any time during the program press the Up or Down key. This will only affect the workload for the present position in the profile. When the profile changes to the next column it will return to the preset work level.
8. During the Strength program you will be able to scroll through the data in the message window by pressing the **Enter key**.
9. When the program ends you may press Start to begin the same program again or Stop to exit the program or you can save the program you just completed as a **custom user program** by pressing a User key and following the instructions in the message window.

## Interval

The **Interval** program takes you through high levels of intensity followed by periods of low intensity. This program increases your endurance by depleting your oxygen level followed by periods of recovery to replenish oxygen. Your cardio vascular system gets programmed to use oxygen more efficiently this way. To start the Interval program follow the instructions below or just press the Interval button then the Enter button and follow the directions in the message window.

1. Press the **Interval** key then press the **Enter** key.
2. The message window will ask you to enter your **Age**. You may enter your Age, using the Up and Down keys or the numeric key pad, then press the Enter key to accept the new number and proceed on to the next screen.

3. You are now asked to enter your **Weight**. You may adjust the Weight number using the Up and Down keys or the numeric key pad, then press enter to continue.
4. Next is **Time**. You may adjust the Time and press enter to continue.
5. Now you are asked to adjust the **Max Level**. This is the peak exertion level you will experience during the program. The factory setting is level seven. Adjust the level and then press enter.
6. Now you are finished editing the settings and can begin your workout by pressing the Start key. You can also go back and modify your settings by pressing the Enter key. NOTE: At any time during the editing of Data you can press the Stop key to go back one level, or screen.
7. If you want to increase or decrease the workload at any time during the program press the Up or Down key. This will only affect the workload for the present position in the profile. When the profile changes to the next column it will return to the preset work level.
8. During the Interval program you will be able to scroll through the data in the message window by pressing the **Enter key**.
9. When the program ends you may press Start to begin the same program again or Stop to exit the program or you can save the program you just completed as a **custom user program** by pressing a User key and following the instructions in the message window.

## Custom User Defined Programs

There are two customizable **User** programs that allow you to build and save your own workout. The two programs, **User 1** and **User 2**, operate exactly the same way so there is no reason to describe them separately. You can build your own custom program by following the instructions below or you can save any other preset program you complete as a custom program. Both programs allow you to further personalize it by adding your name.

1. Press the **User 1 or User 2** key. The message window will show a welcome message. If you had previously saved a program the message will contain your name. Then press the **Enter** key to begin programming.
2. When you press enter, the message window will show "Name – A", if there is no name saved. If the name "David" had been previously saved the message window will show "Name – David" and the D will be blinking. If there is a name saved you can change it or you may press the Stop key to keep the name and continue to the next step. If you want to enter a name use the Up and/or the Down key to change the first letter then press Enter to save the first letter and continue to the next letter. When you have finished entering the name press the Stop key to save the name and continue to the next step.
3. The message window will ask you to enter your **Age**. You may enter your Age, using the Up and Down keys or the numeric key pad, then press the Enter key to accept the new number and proceed on to the next screen.
4. You are now asked to enter your **Weight**. You may adjust the Weight number using the Up and Down keys or the numeric key pad, then press enter to continue.
5. Next is **Time**. You may adjust the Time and press enter to continue.
6. Now you are asked to adjust the **Max Level**. This is the peak exertion level you will experience during the program. The factory setting is level seven. Adjust the level and then press enter.
7. Now the first column will be blinking and you are asked to adjust the level for the first

- segment of the workout. When you finish adjusting the first segment, or if you don't want to change, then press enter to continue to the next segment.
8. The next segment will show the same level as the previously adjusted segment. Repeat the same process as the last segment then press enter. Continue this process until all twenty segments have been set.
  9. The message window will then tell you to press enter to save the program. After saving the program the message window says "New program saved" then will give you the option to Start or modify the program. Pressing Stop will exit to the start up screen.
  10. If you want to increase or decrease the workload at any time during the program press the Up or Down key. This will only affect the workload for the present position in the profile. When the profile changes to the next column it will return to the preset work level.
  11. During the User 1 or User 2 program you will be able to scroll through the data in the message window by pressing the **Enter key**.

## Heart Rate programs

### Before we get started, a word about Heart Rate:

The old motto, “no pain, no gain”, is a myth that has been overpowered by the benefits of exercising comfortably. A great deal of this success has been promoted by the use of heart rate monitors. With the proper use of a heart rate monitor, many people find that their usual choice of exercise intensity was either too high or too low and exercise is much more enjoyable by maintaining their heart rate in the desired benefit range.

To determine the benefit range in which you wish to train, you must first determine your Maximum Heart Rate. This can be accomplished by using the following formula: 220 minus your age. This will give you the Maximum heart rate (MHR) for someone of your age. To determine the effective heart rate range for specific goals you simply calculate a percentage your MHR. Your Heart rate training zone is 50% to 90% of your maximum heart rate. 60% of your MHR is the zone that burns fat while 80% is for strengthening the cardio vascular system. This 60% to 80% is the zone to stay in for maximum benefit.

For someone who is 40 years old their target heart rate zone is calculated:

$$\begin{aligned} 220 - 40 &= 180 \text{ (maximum heart rate)} \\ 180 \times .6 &= 108 \text{ beats per minute (60\% of maximum)} \\ 180 \times .8 &= 144 \text{ beats per minute (80\% of maximum)} \end{aligned}$$

So for a 40 year old the training zone would be 108 to 144 beats per minute.

If you enter your age during programming the console will perform this calculation automatically. Entering your age is used for the Heart Rate control programs and also for the Heart rate bar graph. After calculating your Maximum Heart Rate you can decide upon which goal you would like to pursue.

The two most popular reasons for, or goals, of exercise are cardiovascular fitness (training for the heart and lungs) and weight control. The black columns on the chart below represent the Maximum Heart Rate for a person whose age is listed at the bottom of each column. The training heart rate, for either cardiovascular fitness or weight loss, is represented by two different lines that cut diagonally through the chart. A definition of the lines' goal is in the bottom left-hand corner of the chart. If your goal is cardiovascular fitness or if it is weight loss, it can be achieved by training at 80% or 60%, respectively, of your Maximum Heart Rate on a schedule approved by your physician. Consult your physician before participating in any exercise program.

With all SOLE Heart Rate Control elliptical machines you may use the heart rate monitor feature without using the Heart Rate Control program. This function can be used during manual mode or during any of the nine different programs. The Heart Rate Control program automatically controls resistance at the pedals.

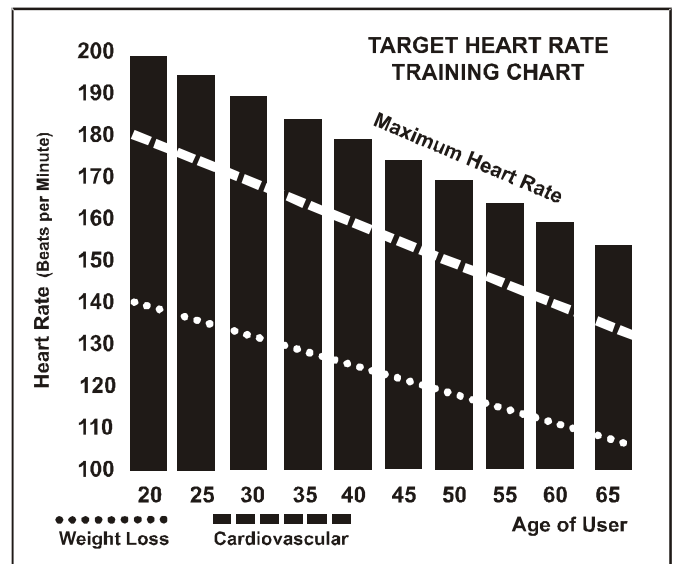

## Rate of Perceived Exertion

Heart rate is important but listening to your body also has a lot of advantages. There are more variables involved in how hard you should workout than just heart rate. Your stress level, physical health, emotional health, temperature, humidity, the time of day, the last time you ate and what you ate, all contribute to the intensity at which you should workout. If you listen to your body, it will tell you all of these things.

The rate of perceived exertion (RPE), also know as the Borg scale, was developed by Swedish physiologist G.A.V. Borg. This scale rates exercise intensity from 6 to 20 depending upon how you feel or the perception of your effort.

The scale is as follows:

### Rating Perception of Effort

- 6 Minimal
- 7 Very,very light
- 8 Very,very light +
- 9 Very light
- 10 Very light +
- 11 Fairly light
- 12 Comfortable
- 13 Somewhat hard
- 14 Somewhat hard +
- 15 Hard
- 16 Hard +
- 17 Very hard
- 18 Very hard +
- 19 Very,very hard
- 20 Maximal

You can get an approximate heart rate level for each rating by simply adding a zero to each rating. For example a rating of 12 will result in an approximate heart rate of 120 beats per minute. Your RPE will vary depending up the factors discussed earlier. That is the major benefit of this type of training. If your body is strong and rested, you will feel strong and your pace will feel easier. When your body is in this condition, you are able to train harder and the RPE will support this. If you are feeling tired and sluggish, it is because your body needs a break. In this condition, your pace will feel harder. Again, this will show up in your RPE and you will train at the proper level for that day.



## Using a Heart Rate Transmitter

How to wear your wireless chest strap transmitter:

1. Attach the transmitter to the elastic strap using the locking parts.
2. Adjust the strap as tightly as possible as long as the strap is not too tight to remain comfortable.
3. Position the transmitter with the SOLE logo centered in the middle of your body facing away from your chest (some people must position the transmitter slightly left of center). Attach the final end of the elastic strap by inserting the round end and, using the locking parts, secure the transmitter and strap around your chest.
4. Position the transmitter immediately below the pectoral muscles.
5. Sweat is the best conductor to measure very minute heart beat electrical signals. However, plain water can also be used to pre-wet the electrodes (2 black square areas on the reverse side of the belt and either side of transmitter). It's also recommended that you wear the transmitter strap a few minutes before your work out. Some users, because of body chemistry, have a more difficult time in achieving a strong, steady signal at the beginning. After "warming up", this problem lessens. As noted, wearing clothing over the transmitter/strap doesn't affect performance.
6. Your workout must be within range - distance between transmitter/receiver – to achieve a strong steady signal. The length of range may vary somewhat but generally stay close enough to the console to maintain good, strong, reliable readings. Wearing the transmitter immediately against bare skin assures you of proper operation. If you wish, you may wear the transmitter over a shirt. To do so, moisten the areas of the shirt that the electrodes will rest upon.

*Note: The transmitter is automatically activated when it detects activity from the user's heart. Additionally, it automatically deactivates when it does not receive any activity. Although the transmitter is water resistant, moisture can have the effect of creating false signals, so you should take precautions to completely dry the transmitter after use to prolong battery life (estimated transmitter battery life is 2500 hours). The replacement battery is Panasonic CR2032.*

### Erratic Operation:

**Caution! Do not use this elliptical for Heart Rate Control unless a steady, solid Actual Heart Rate value is being displayed. High, wild, random numbers being displayed indicate a problem.**

**Areas to look for interference which may cause erratic heart rate:**

- (1) Microwave ovens, TV's, small appliances, etc.
- (2) Fluorescent lights.
- (3) Some household security systems.
- (4) Perimeter fence for a pet.
- (5) Some people have problems with the transmitter picking up a signal from their skin. If you have problems try wearing the transmitter upside down. Normally the transmitter will be oriented so the SOLE logo is right side up.
- (6) If you continue to experience problems contact your dealer.



# Using a Heart Rate Transmitter

How to wear your wireless chest strap transmitter:

1. Attach the transmitter to the elastic strap using the locking parts.
2. Adjust the strap as tightly as possible as long as the strap is not too tight to remain comfortable.
3. Position the transmitter with the SOLE logo centered in the middle of your body facing away from your chest (some people must position the transmitter slightly left of center). Attach the final end of the elastic strap by inserting the round end and, using the locking parts, secure the transmitter and strap around your chest.
4. Position the transmitter immediately below the pectoral muscles.
5. Sweat is the best conductor to measure very minute heart beat electrical signals. However, plain water can also be used to pre-wet the electrodes (2 black square areas on the reverse side of the belt and either side of transmitter). It's also recommended that you wear the transmitter strap a few minutes before your work out. Some users, because of body chemistry, have a more difficult time in achieving a strong, steady signal at the beginning. After "warming up", this problem lessens. As noted, wearing clothing over the transmitter/strap doesn't affect performance.
6. Your workout must be within range - distance between transmitter/receiver – to achieve a strong steady signal. The length of range may vary somewhat but generally stay close enough to the console to maintain good, strong, reliable readings. Wearing the transmitter immediately against bare skin assures you of proper operation. If you wish, you may wear the transmitter over a shirt. To do so, moisten the areas of the shirt that the electrodes will rest upon.

*Note: The transmitter is automatically activated when it detects activity from the user's heart. Additionally, it automatically deactivates when it does not receive any activity. Although the transmitter is water resistant, moisture can have the effect of creating false signals, so you should take precautions to completely dry the transmitter after use to prolong battery life (estimated transmitter battery life is 2500 hours). The replacement battery is Panasonic CR2032.*

## Erratic Operation:

**Caution! Do not use this elliptical for Heart Rate Control unless a steady, solid Actual Heart Rate value is being displayed. High, wild, random numbers being displayed indicate a problem.**

**Areas to look for interference which may cause erratic heart rate:**

- (1) Microwave ovens, TV's, small appliances, etc.
- (2) Fluorescent lights.
- (3) Some household security systems.
- (4) Perimeter fence for a pet.
- (5) Some people have problems with the transmitter picking up a signal from their skin. If you have problems try wearing the transmitter upside down. Normally the transmitter will be oriented so the SOLE logo is right side up.
- (6) If you continue to experience problems contact your dealer.

## Heart Rate Control Program 1 & 2 (HR 1, HR 2) operation

Both programs operate the same, the only difference is that HR 1 is set to 60% and HR 2 is set to 80% of maximum heart rate. They both are programmed the same way.

To start the **HR 1 or HR 2** programs follow the instructions below or just press the HR 1 or HR 2 button then the Enter button and follow the directions in the message window.

10. Press the **HR 1 or HR 2** key then press the **Enter** key.
11. The message window will ask you to enter your **Age**. You may enter your Age, using the Up and Down keys or the numeric key pad, then press the Enter key to accept the new number and proceed on to the next screen.
12. You are now asked to enter your **Weight**. You may adjust the Weight number using the Up and Down keys or the numeric key pad, then press enter to continue.
13. Next is **Time**. You may adjust the Time and press enter to continue.
14. Now you are asked to adjust the **Heart rate Level**. This is the heart rate level you will experience during the program. Adjust the level and then press enter.
15. Now you are finished editing the settings and can begin your workout by pressing the Start key. You can also go back and modify your settings by pressing the Enter key.  
NOTE: At any time during the editing of Data you can press the Stop key to go back one level, or screen.
16. If you want to increase or decrease the workload at any time during the program press the Up or Down key. This will allow you to change your target heart rate at any time during the program.
17. During the HR 1 or HR 2 programs you will be able to scroll through the data in the message window by pressing the **Enter key**.
18. When the program ends you may press Start to begin the same program again or Stop to exit the program or you can save the program you just completed as a **custom user program** by pressing a User key and following the instructions in the message window.

## Auto-Pilot feature (E55 model only)

This unique feature allows the user to instantly enter the Heart Rate Control mode at any time with the press of a button.

The HR2 program button also doubles as the Auto-Pilot button. During any program the user may press the Auto-Pilot button to enter the HRC program. Your current heart rate (the current heart rate at the moment you press the Auto-Pilot button) will be maintained automatically by the Auto-Pilot program. You may press the elevation/incline up or down buttons to change your target heart rate while in the Auto-Pilot mode.

## Maintenance:

1. Wipe down all areas in the sweat path with a damp cloth after each workout.
2. If a squeak, thump, clicking or rough feeling develops the main cause is most likely one of two reasons:
  - i. The hardware was not sufficiently tightened during assembly. All bolts that were installed during assembly need to be tightened as much as possible. It may be necessary to use a larger wrench than the one provided if you cannot tighten the bolts sufficiently. I cannot stress this point enough; 90% of calls to the service department for noise issues can be traced to loose hardware or the rear rails being dirty.
  - ii. Dirt build-up on the rear rails and polyurethane wheels are also a source of noise. Noise from build-up on the rails can cause a thumping sound that you would swear is coming from inside the main body of the machine because noise travels, and is amplified, in the tubing of the frame. Clean the rails and wheels with a lint free cloth and rubbing alcohol. Stubborn build-up can be removed with your thumbnail or a non-metallic scraper, like the back edge of a plastic knife. After cleaning, apply a small amount of lubricant on the rails with your fingers or a lint free cloth. You only need a thin coat of lubrication, wipe off any excess.
3. If squeaks or other noises persist, check that the unit is properly leveled. There are 4 leveling pads on the bottom of the rear rails, use a 14mm wrench (or adjustable wrench) to adjust the levelers.

## Maintenance Menu in console software:

The console has built in maintenance/diagnostic software. The software will allow you to change the console settings from English to Metric and turn off the beeping of the speaker when a key is pressed for example. To enter the Maintenance menu (may be called Engineering mode, depending on version) press and hold down the Start, Stop and Enter keys. Keep holding the keys down for about 5 seconds and the message window will display "ALTXXX Engineering mode". Press the enter button to access the menu below:

- a. **Key test** (will allow you to test all the keys to make sure they are functioning)
- b. **Display test** (tests all the display functions)
- c. **Functions** (Press enter to access settings)
  - i. **Sleep mode** (Turn on to have the console power down automatically after 20 minutes of inactivity)
  - ii. **Pause Mode** (Turn on allow 5 minutes of pause, turn off to have the console pause indefinitely)
  - iii. **ODO reset** (reset the odometer)
  - iv. **Units** (Set to English or Metric display readings)
  - v. **Beep** (Turn on or off the beep when a key is pressed)
  - vi. **Motor test** (continually runs the tensioning gear motor)
  - vii. **Exit**
- d. **Security** (Allows you to lock the keypad so no unauthorized use is allowed)
- e. **Factory settings** (Access only allowed by manufacturing)

# Manufacturer's Limited Warranty

## Effective January 1, 2007 ELLIPTICAL WARRANTY

SOLE warrants all its elliptical parts for a period of 3 years from the date of retail sale, as determined by sale receipt, or in the absence of a sales receipt eighteen (18) months from the original factory shipping date. SOLE's responsibilities include providing new or remanufactured parts, at SOLE's option, and technical support to our independent dealers and servicing organizations. In the absence of a dealer or service organization, these warranties will be administered by SOLE directly to a consumer. An extended warranty period applies to the following components:

<b>E25</b>		<b>E55</b>	
Labor	1 years	Labor	2 years
Frame Weldments	Lifetime	Frame Weldments	Lifetime
Brake	Lifetime	Brake	Lifetime
All Other Components	3 years	All other Components	5 years

### NORMAL RESPONSIBILITIES OF THE CONSUMER

This warranty applies only to products in ordinary household use, and the consumer is responsible for the items listed below:

1. The warranty registration card must be completed and returned to the address listed on the card within 10 days of the original purchase to validate the manufacturer's limited warranty.
2. Proper use of the elliptical in accordance with the instructions provided in this manual
3. Proper installation in accordance with instructions provided with the elliptical and with all local electric codes.
4. Proper connection to a grounded power supply of sufficient voltage, replacement of blown fuses, repair of loose connections or defects in house wiring.
5. Expenses for making the elliptical accessible for servicing, including any item that was not part of the elliptical at the time it was shipped from the factory.
6. Damages to the elliptical finish during shipping, installation or following installation.

### EXCLUSIONS

This warranty does not cover the following:

1. CONSEQUENTIAL, COLLATERAL, OR INCIDENTAL DAMAGES SUCH AS PROPERTY DAMAGE AND INCIDENTAL EXPENSES RESULTING FROM ANY BREACH OF THIS WRITTEN OR ANY IMPLIED WARRANTY.  
*Note: Some states do not allow the exclusion or limitation of incidental or consequential damages, so this limitation or exclusion may not apply to you.*
2. Service call reimbursement to the consumer. Service call reimbursement to the dealer that does not involve malfunction or defects in workmanship or material, for units that are beyond the warranty period, for units that are beyond the service call reimbursement period, for elliptical not requiring component replacement, or elliptical not in ordinary household use.
3. Damages caused by services performed by persons other than authorized SOLE service companies; use of parts other than original SOLE parts; or external causes such as alterations, modifications, abuse, misuse, accident, improper maintenance, inadequate power supply, or acts of God.
4. Products with original serial numbers that have been removed or altered.
5. Products that have been sold, transferred, bartered, or given to a third party.
6. Products that do not have a warranty registration card on file at SOLE. SOLE reserves the right to request proof of purchase if no warranty record exists for the product.
7. THIS WARRANTY IS EXPRESSLY IN LIEU OF ALL OTHER WARRANTIES EXPRESSED OR IMPLIED, INCLUDING THE WARRANTIES OF MERCHANTABILITY AND/OR FITNESS FOR A PARTICULAR PURPOSE.

### SERVICE

Keep your bill of sale. Twelve (12) months from the date on the bill of sale or eighteen (18) months from the date of factory shipping as determined by the serial number establishes the labor warranty period should service be required. If service is performed, it is in your best interest to obtain and keep all receipts. This written warranty gives you specific legal rights. You may also have other rights that vary from state to state. Service under this warranty must be obtained by following these steps, in order:

1. Contact your selling authorized SOLE dealer. OR
2. Contact your local authorized SOLE service organization.
3. If there is a question as to where to obtain service, contact our service department at 866-MYSOLE1 (697-6531).
4. If no local service is available, SOLE will repair or replace the parts, at SOLE's option, within the warranty period at no charge for parts. All transportation costs, both to our factory and upon return to the owner, are the responsibility of the owner. The owner is responsible for adequate packaging upon return to SOLE. SOLE is not responsible for damages in shipping. Make all freight damage claims with the appropriate freight carrier. DO NOT SHIP ANY UNIT TO OUR FACTORY WITHOUT A RETURN AUTHORIZATION NUMBER. All units arriving without a return authorization number will be refused.
5. For any further information, or to contact our service department by mail, send your correspondence to:

**SOLE Fitness  
P.O. Box 2037  
Jonesboro, AR 72402-2037**

Product features or specifications as described or illustrated are subject to change without notice. All warranties are made by SOLE. This warranty applies only in the 50 states of the U.S.A.